

RB-WATCHER

THE AUTONOMOUS
MOBILE ROBOT FOR
**INTELLIGENT
INSPECTION**



Engineered for reliable **inspections**

Inspection tasks demand precision and reliability to detect and prevent anomalies in critical assets.

RB-WATCHER, Robotnik's autonomous robotic platform, offers a safe and efficient way to perform inspection missions in complex environments.

Equipped with advanced sensors, it enables thermal inspections, intelligent visual recognition, people or vehicle detection or autonomous patrolling ensuring intelligent, reliable and continuous inspection for greater operational efficiency.

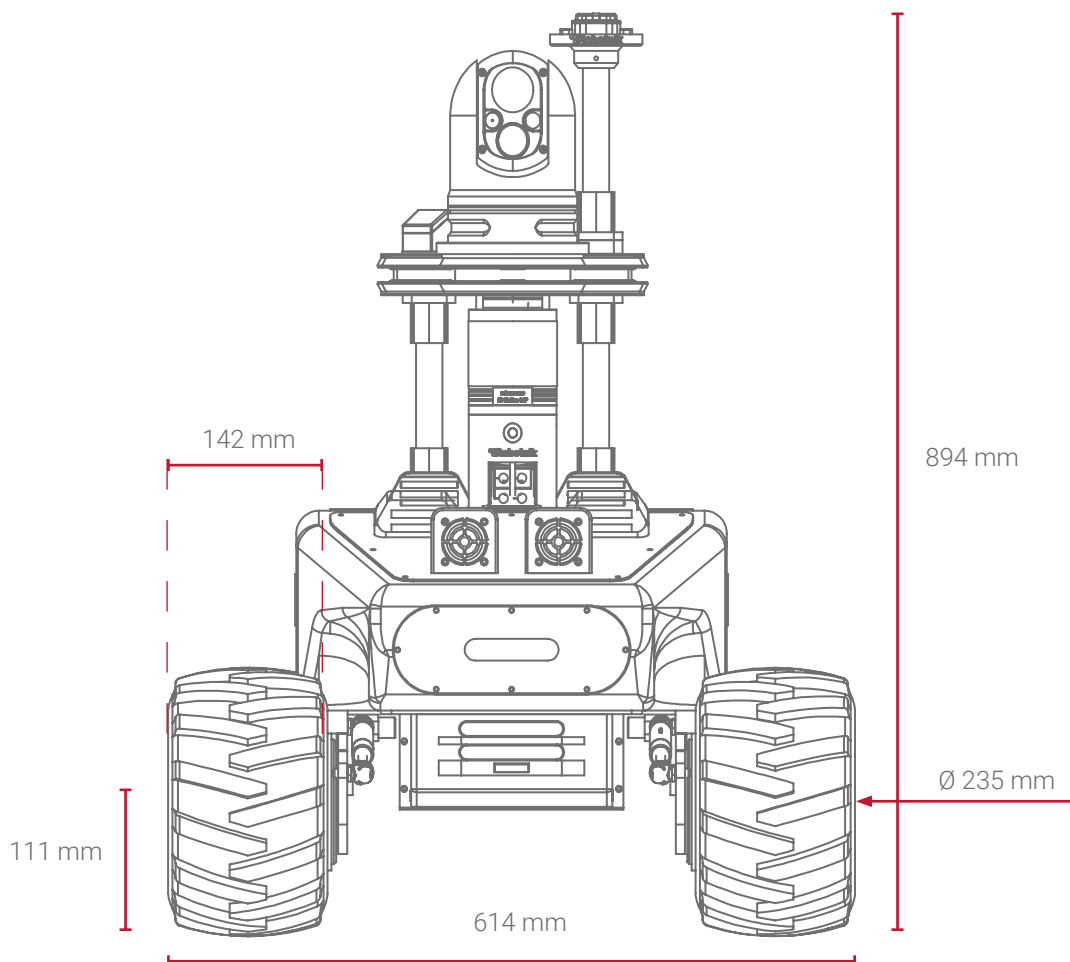

All terrain AMR



2,5 m/s



IP54



50 kg



5 hours



65%



-10°C <=> 45°C

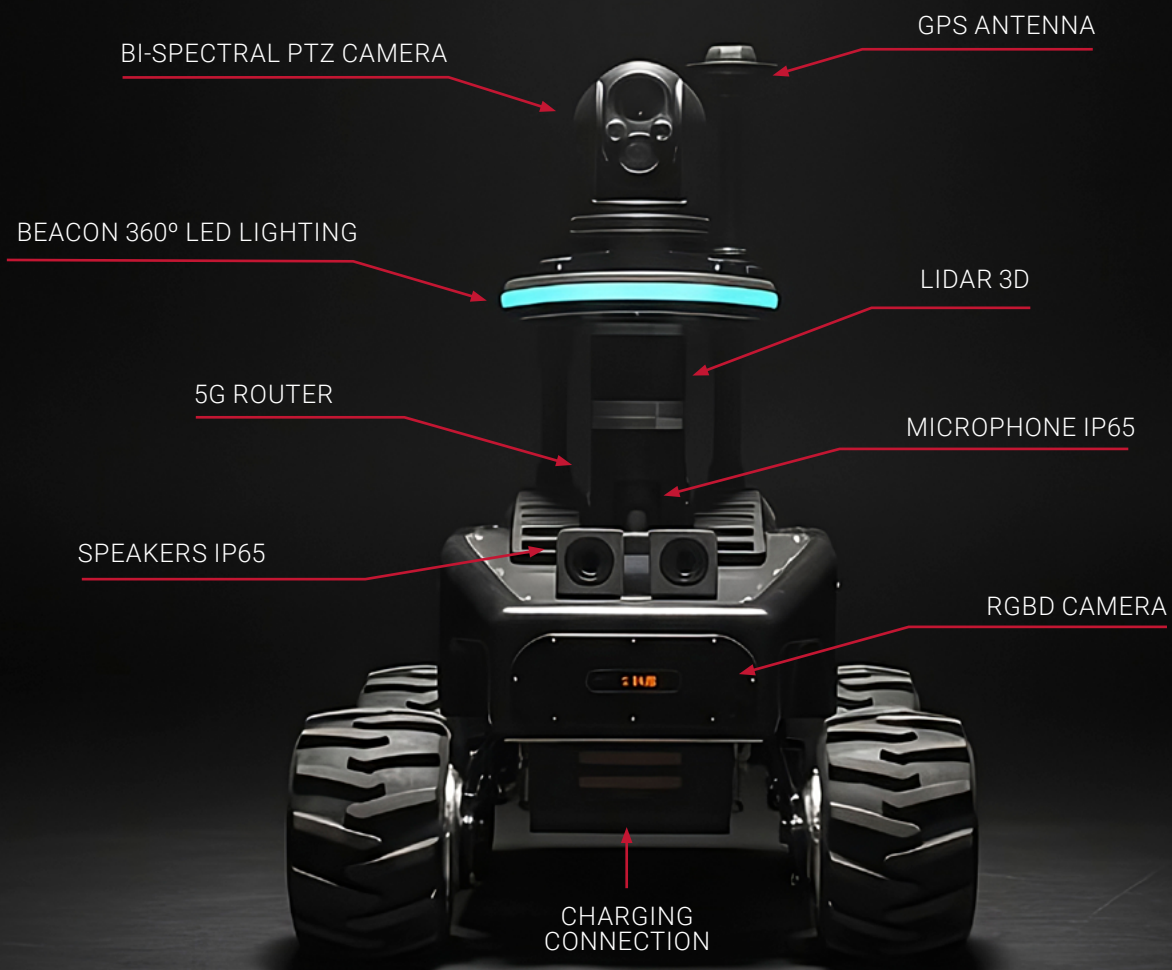

Main benefits of **RB-WATCHER**



Reliability

Performs precise and repeatable inspections of infrastructures, ensuring consistent data collection and reducing the risk of overlooking anomalies in critical assets.

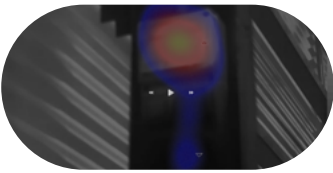

Incident reduction

Access to various sensors such as a thermographic camera, provide the inspection staff with data beyond human perception.

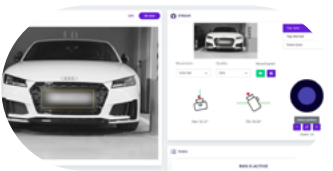

User-friendly HMI

Human-Machine Interface developed by **Robotnik**, enabling operators to create maps, define key zones, program autonomous tasks, teleoperate the robot and access real-time inspection data.

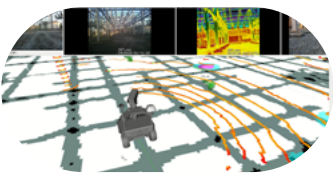

Artificial Intelligence

Integrates advanced AI and vision recognition modules to continuously analyze images, detect trained elements, trigger alerts, apply privacy filters, and enhance inspection accuracy.



Modular configuration

Expansion port to integrate additional modules according to application, thus extending the robot capabilities and adapting to different tasks and environments.

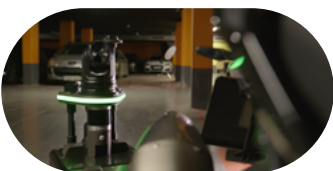

Data-driven decision making

Collects and transmits visual, thermal and acoustic information in real time, providing operators with reliable insights for faster and better decisions.



Operational efficiency

Automates inspection routines in large or complex environments, reducing downtime, optimizing resources and increasing the overall productivity of industrial operations.



ROI - Return On Investment

Ensures return on investment by automating inspection routines, reducing operational costs, minimizing downtime, and maximizing efficiency while protecting critical and high-value assets.

Ready for

inspection tasks

RB-WATCHER redefines industrial inspection and security operations through intelligent automation.

Its advanced vision, thermal and navigation systems enable precise detection of thermal anomalies, vehicles or people while autonomously patrolling large infrastructures.

Designed to optimize safety and efficiency, it supports operators by minimizing risks, improving response times and reducing operational costs through continuous, data-driven monitoring.

- Real time monitoring of the cameras and sensors
- Autonomous patrolling of a pre-defined area
- Anomaly detection (fence breakage)
- Intelligent visual recognition
- Remote turn on/off
- Video transmission
- Thermal inspection
- Collection of data
- People recognition
- Vehicle detection



New

Human-Machine Interface (HMI)

Manage, monitor and act with precision from any device

The advanced **User Interface – HMI** is a proprietary development by **Robotnik** that allows intuitive and agile control of the robot's functionalities.

Access the HMI through any web browser by connecting to the same network as the robot, then follow the

steps described in the **Control Interface Manual** to log in and complete the initial configuration.

From that moment, you'll have access to the different panels, navigation pages and available features.

2

AUTONOMOUS MISSION PROGRAMMING

3

REAL-TIME MONITORING & ANALYSIS

5

USER & PERMISSIONS MANAGEMENT

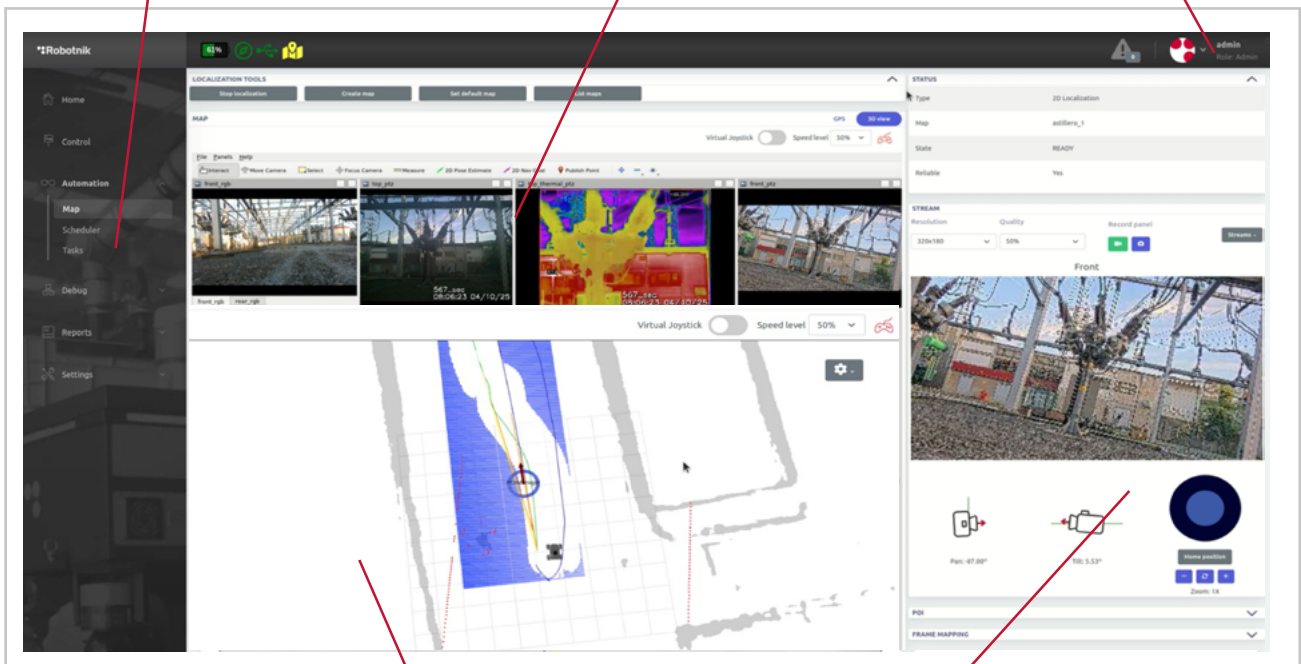

1

MAP & AREAS OF INTEREST

4

REMOTE TELEOPERATION & CAMERAS

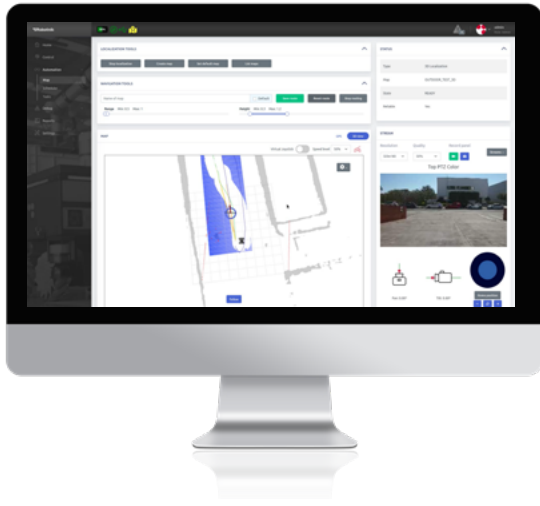

1. Map & areas of interest

Create and edit custom maps, define critical points and configure patrol routes.

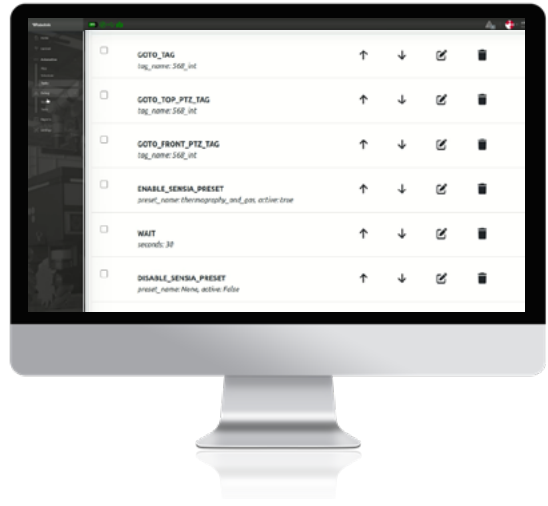

2. Autonomous mission programming

Set up automatic tasks, scheduled routes and adjustments based on time or operational conditions.



3. Real-time monitoring & analysis

Track system metrics, sensor data, history and early anomaly detection.



4. Remote teleoperation & cameras

Get direct visual access and manually control the robot remotely when needed.

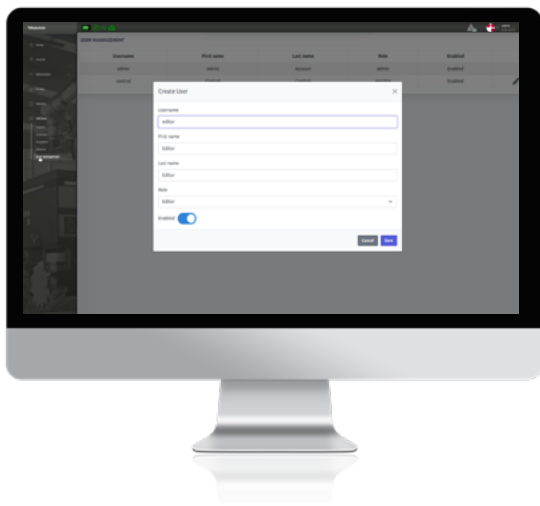

5. User & permissions management

Define user roles (operator, supervisor, developer) and ensure secure, controlled access.



Want to know more?
View full video

MAKE IT BIGGER









RB-WATCHER^{XL}

More mobility, more autonomy, same intelligence

RB-WATCHER XL is a version of **Robotnik**'s inspection and security robot **RB-WATCHER**, developed to meet the needs of environments or applications that, by their nature, require greater autonomy, robustness and mobility.

Its main differences compared to the **RB-WATCHER** lie in a larger chassis and all-terrain wheels, allowing it to overcome obstacles up to 14 cm, providing greater mobility and stability.

In addition, it features a longer battery life, remote power control, and an Easy Swap battery system. Alongside the **RB-WATCHER**'s native integration of speakers and microphone, it now also includes integrated front LED lights.

 1,5 m/s	 IP55
 10 hours	 50%
 -10°C <> 40°C	 14 cm

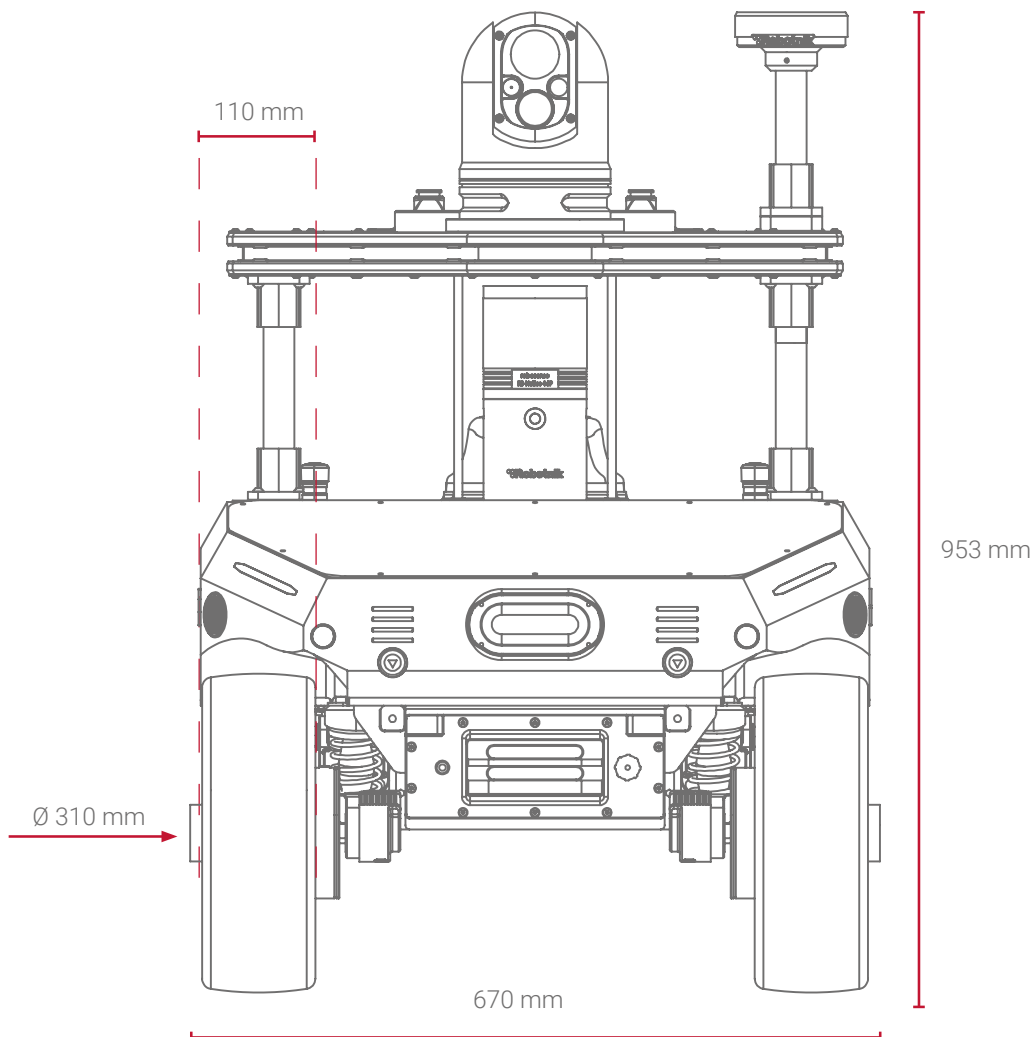

Additional benefits of **RB-WATCHERXL**



Larger chassis and all-terrain wheels, capable of overcoming obstacles up to 14 cm, improving mobility and stability on uneven surfaces.



Extended operational autonomy, with a 29A battery that significantly increases the robot's working time without interruptions.



Easy Swap battery, removable and easily replaceable by the user. Allows the use of additional batteries to maintain continuous operation without charging downtime; the robot can also be transported without the battery to simplify logistics.

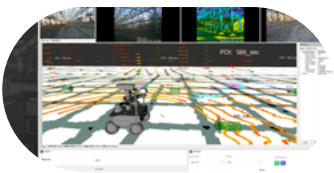

Remote power on/off, optimizing remote management and operational control.



IP55 protection, ensuring resistance against dust, rain, and harsh environmental conditions.



Native integration of speakers, LED lights, and microphone, enhancing communication, visibility and interaction during operations.

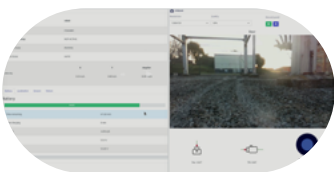

Ready for GPU / ZedBox integration, expanding its processing, advanced vision and artificial intelligence capabilities.



Improved accessibility, facilitating maintenance tasks and the integration of new components or sensors.

Autonomous inspection in an electrical substation

EDP, one of Europe's leading energy groups, has implemented the **RB-WATCHER XL** in one of its electrical substations to enhance safety, reliability and efficiency in routine inspection and perimeter security tasks.

Challenge

Electrical substations are critical infrastructures that require continuous and precise monitoring to detect anomalies such as overheating, leaks, intrusions or equipment failures.

Traditional manual inspections involve safety risks for personnel and provide limited coverage, especially in large or hard-to-access outdoor environments.



Autonomous inspection in an electrical substation

Solution

EDP has integrated the **RB-WATCHER XL** to perform autonomous patrols and inspections within the substation.

Equipped with thermal and visual cameras, a LiDAR sensor, and AI-based recognition modules, the robot continuously monitors the environment, detects thermal anomalies or unusual elements and transmits real-time data and alerts to the control center, ensuring precise and uninterrupted supervision of the infrastructure.

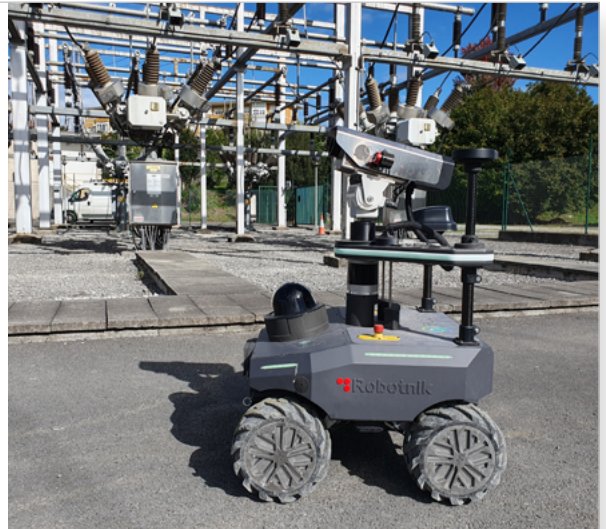

Results

Darío González, from EDP:

“This autonomous inspection robot provides benefits on human, economic and ecological levels.

RB-WATCHER XL enables us to carry out more accurate and frequent inspections, identify potential issues early and reduce the risk of power supply interruptions”.



CONTINUOUS &
AUTONOMOUS
OPERATION



REMOTE MANAGEMENT
THROUGH HMI



EARLY ANOMALY
DETECTION



ENHANCED
WORKER SAFETY



DATA-DRIVEN
DECISION MAKING

+20 YEARS
LEADING
MOBILE
ROBOTICS



Do you have a project in mind?

 sales@robotnik.eu